

The use or communication of the contents there of are forbidden without express authority. (당사의 사전 허락없이 무단 전제 및 복사를 금함)

NO	REVISION RECORD	DATE	CHK.	APPR.

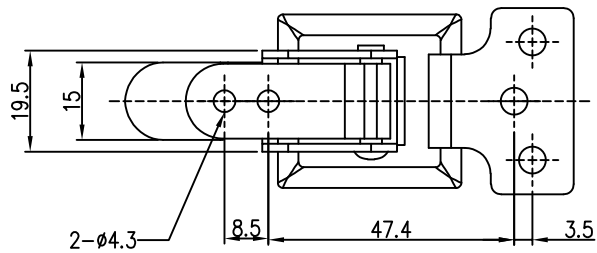

CC-1096-1

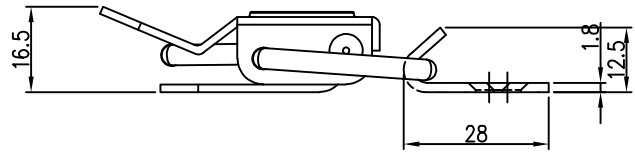
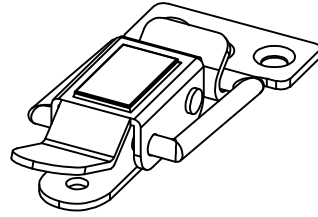
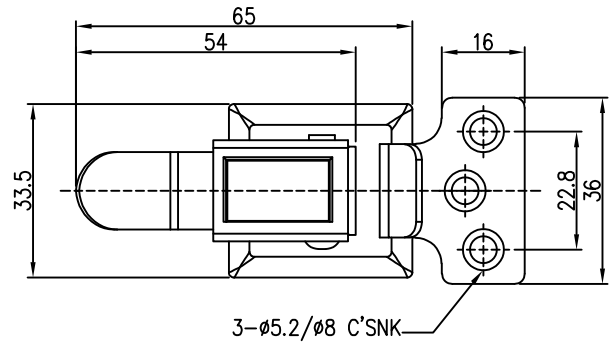
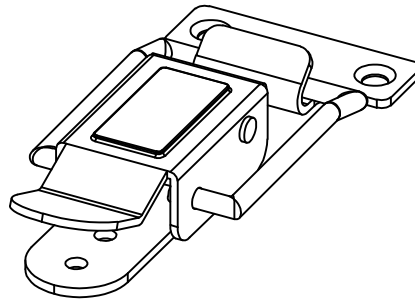
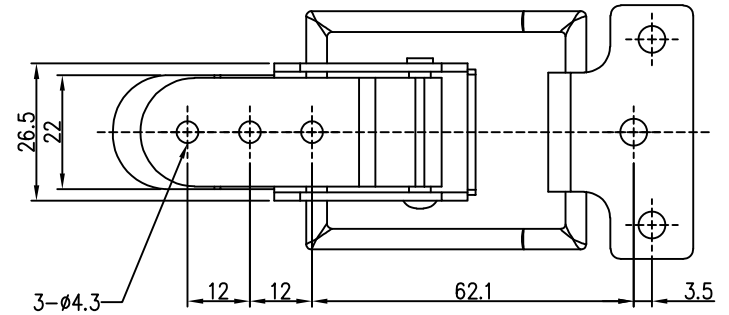
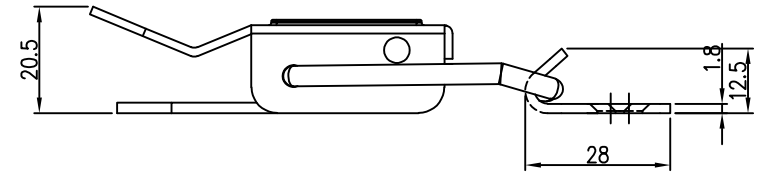
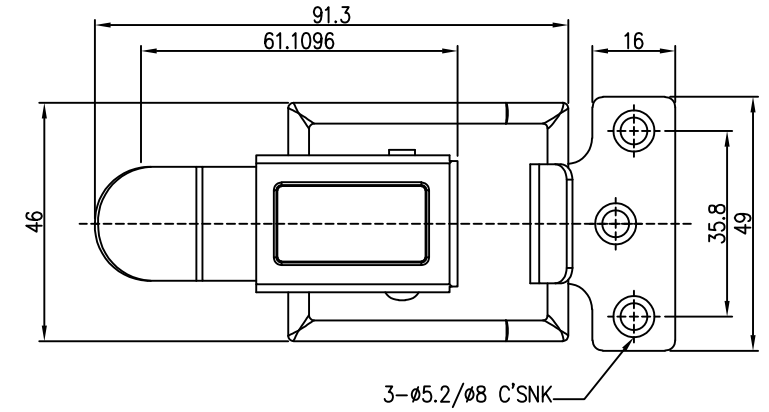

CC-1096-2

TOLERANCE(mm) (KS B 0412에 준함)	
6 이하	±0.05
6 ~ 30	±0.1
30 ~ 120	±0.15
120 ~ 315	±0.2
300 ~ 1000	±0.3
1000 ~ 2000	±0.5

Note

- 재질:
- 외관사양:

FINISH	MATERIAL	UNIT	mm	NO.	DESCRIPTION	DWG. NO	QTY	REMARK
아연도금	Steel	APP.			DWG. NO.	-		V1.0
		DWG.	2023. 12. 10		PART NAME			
QTY				1/1	ASS'Y NAME	목형 매이코리		
1 EA/SET				A3	MODEL NO.	CC-1096		