

The use or communication of the contents there of are forbidden without express authority. (당사의 사전 허락없이 무단 전제 및 복사를 금함)

NO	REVISION RECORD	DATE	CHK.	APPR.

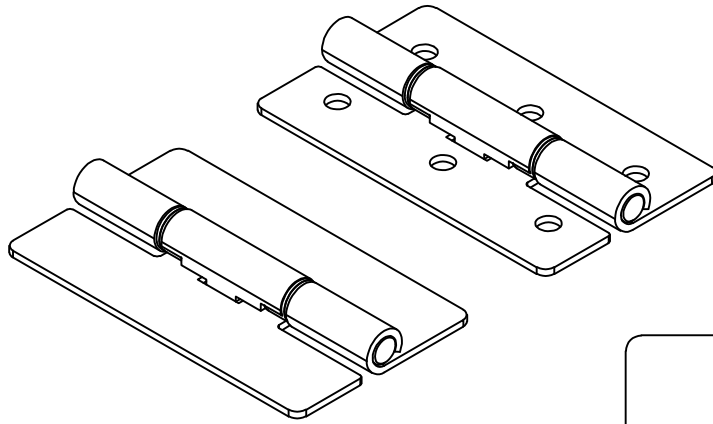

Note

1. 토크값 지정가능 (0.35~1.95N.m)
2. 타공 홀 피치 / 크기 / 갯수 지정가능
3. Torque = +/- 20%
4. 저분진 경첩

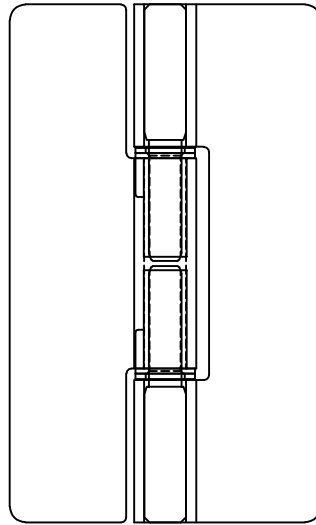

CHT-2023-무공

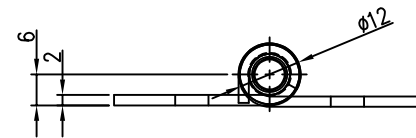
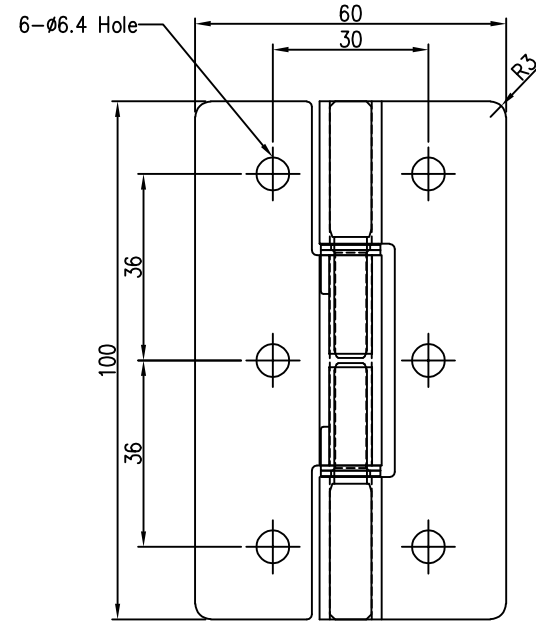

CHT-2023-유공

TOLERANCE(mm) (KS B 0412에 준함)	
6 이하	±0.05
6 ~ 30	±0.1
30 ~ 120	±0.15
120 ~ 315	±0.2
300 ~ 1000	±0.3
1000 ~ 2000	±0.5

FINISH	MATERIAL	UNIT	mm	NO.	DESCRIPTION	DWG. NO	QTY	REMARK
Barrelling 바렐연마	SUS 304 2t	APP. DWG.	2023.11.10		DWG. NO. PART NAME	-		V1.0
QTY	A Solution			1/1	ASS'Y NAME	플랫 토크 경첩/저분진 경첩		
1 EA/SET				A3	MODEL NO.	CHT-2023		