

The use or communication of the contents there of are forbidden without express authority. (당사의 사전 허락없이 무단 전제 및 복사를 금함)

| NO | REVISION RECORD | DATE | CHK. | APPR. |
|----|-----------------|------|------|-------|
|    |                 |      |      |       |

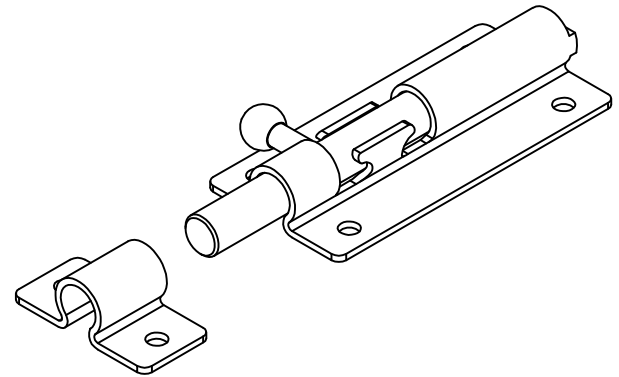

CE-3025

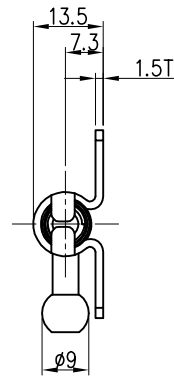
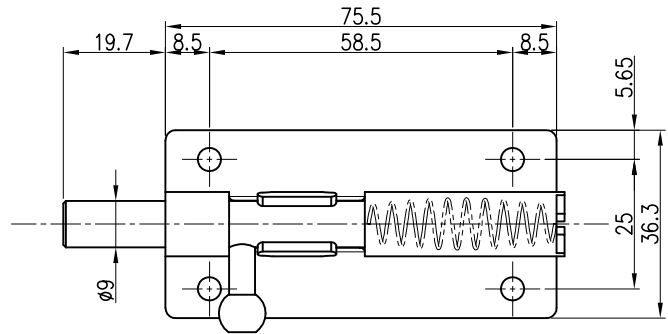
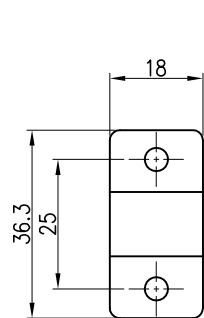
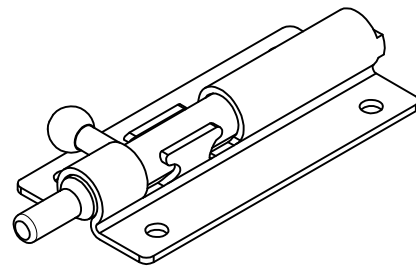
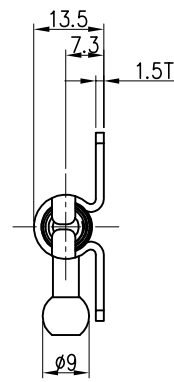
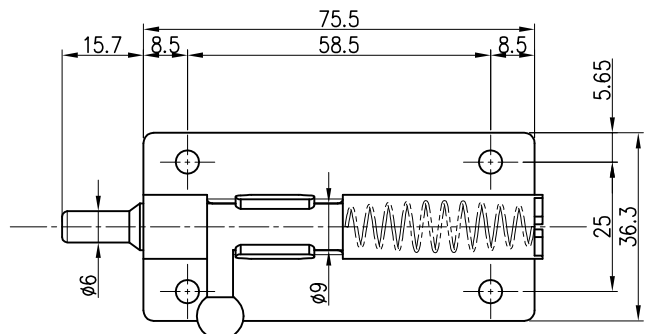

CE-3025(특주품)

| TOLERANCE(mm)<br>(KS B 0412에 준함) |       |
|----------------------------------|-------|
| 6 이하                             | ±0.05 |
| 6 ~ 30                           | ±0.1  |
| 30 ~ 120                         | ±0.15 |
| 120 ~ 315                        | ±0.2  |
| 300 ~ 1000                       | ±0.3  |
| 1000 ~ 2000                      | ±0.5  |

| FINISH   | MATERIAL         | UNIT         | mm         | NO. | DESCRIPTION           | DWG. NO | QTY | REMARK |
|----------|------------------|--------------|------------|-----|-----------------------|---------|-----|--------|
| 헤어라인     | SUS 304<br>t=1.5 | APP.<br>DWG. | 2020.06.01 |     | DWG. NO.<br>PART NAME | -       | -   | V1.0   |
| QTY      | Hardware         |              |            | 1/1 | ASS'Y NAME            | 오도시     |     |        |
| 1 EA/SET | A3               |              |            |     | MODEL NO.             | CE-3025 |     |        |