

The use or communication of the contents there of are forbidden without express authority.(당사의 사전 허락없이 무단 전제 및 복사를 금함)

NO	REVISION RECORD	DATE	CHK.	APPR.

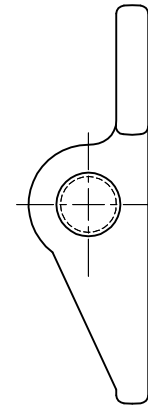
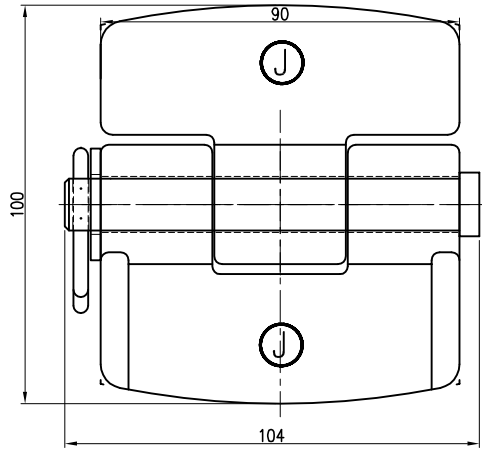
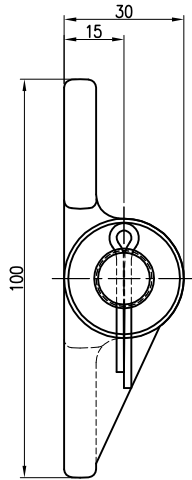
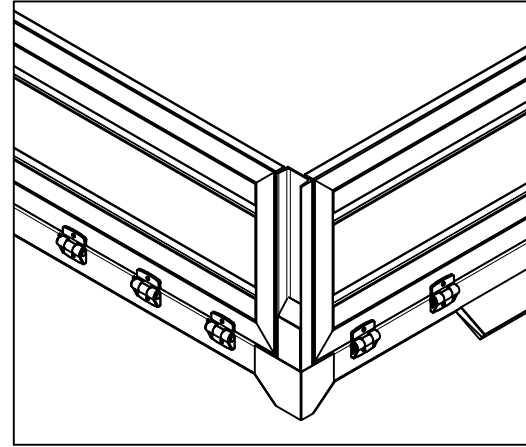
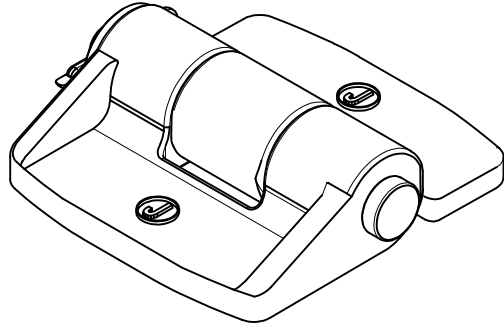

TOLERANCE(mm)  
(KS B 0412에 준함)

6 이하	±0.05
6 ~ 30	±0.1
30 ~ 120	±0.15
120 ~ 315	±0.2
300 ~ 1000	±0.3
1000 ~ 2000	±0.5

Note

- 특징 : 열간단조 공법(아연도금)
- 용도 : 용접용

FINISH	MATERIAL	UNIT	mm	NO.	DESCRIPTION	DWG. NO	QTY	REMARK
도금 : Zinc plating 도장 : -	S45C	APP.			DWG. NO.	-		V1.0
		DWG.	2020.01.20		PART NAME			
QTY				1/1	ASS'Y NAME	특장차 경첩(용접용)		
1 EA/SET	Hardware			A3	MODEL NO.	CH-074		