

YKCT-AR SERIES

높낮이 조절용

제품 특징 FEATURES

- 손쉬운 이동과 고정 높낮이 조절, 방진 및 360도 회전 기능 일체화
- 휠 커버 사용으로 오염이 적음

적용 범위 APPLICATION

- 알루미늄 프로파일로 제작된 프레임, 자동화장비, 반도체 / 디스플레이 제조장비, 컨베이어등.



60F~100F



60S~100S

모델설명 ORDERING CODE

YKCT - AR 60 F/S

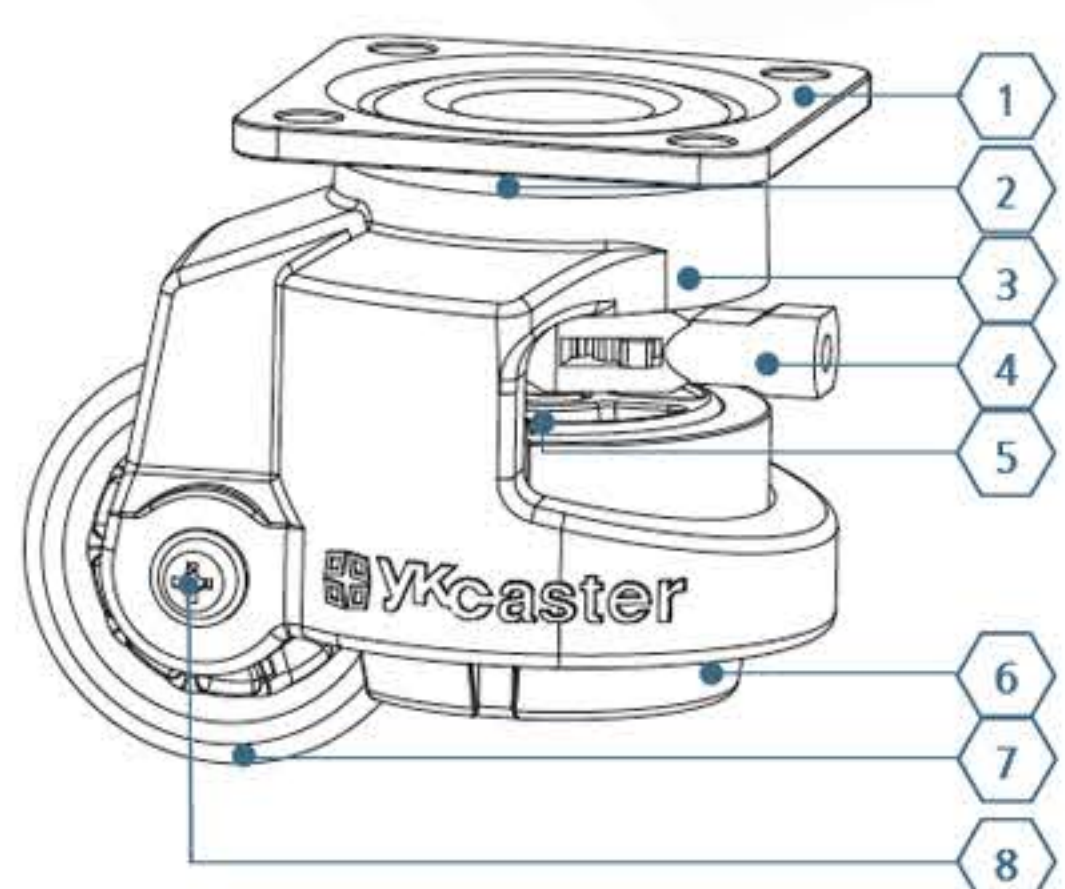
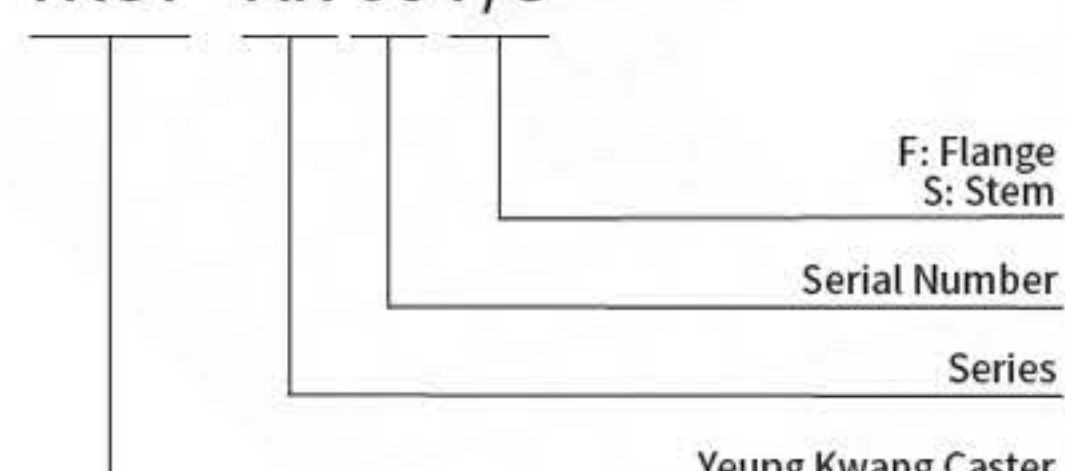

재질 MATERIAL & TREATMENT INFORMATION

No.	재질	표면처리	
1	Caster seat	SPC & S45C	Black Coated
2	Ball	STB2	Ni-Cr
3	Body	ALDC12	Hammertone
4	Handle	ALDC12	Red Coating
5	Rod	Swrch10A	Zn Galvanized
6	Pad	NBR	Black
7	Wheel	PA6	Black
8	Pin	S10C	Zn Galvanized

* Option: Wheel: Antistatic Poly Urethane



60F/80F



60S/80S

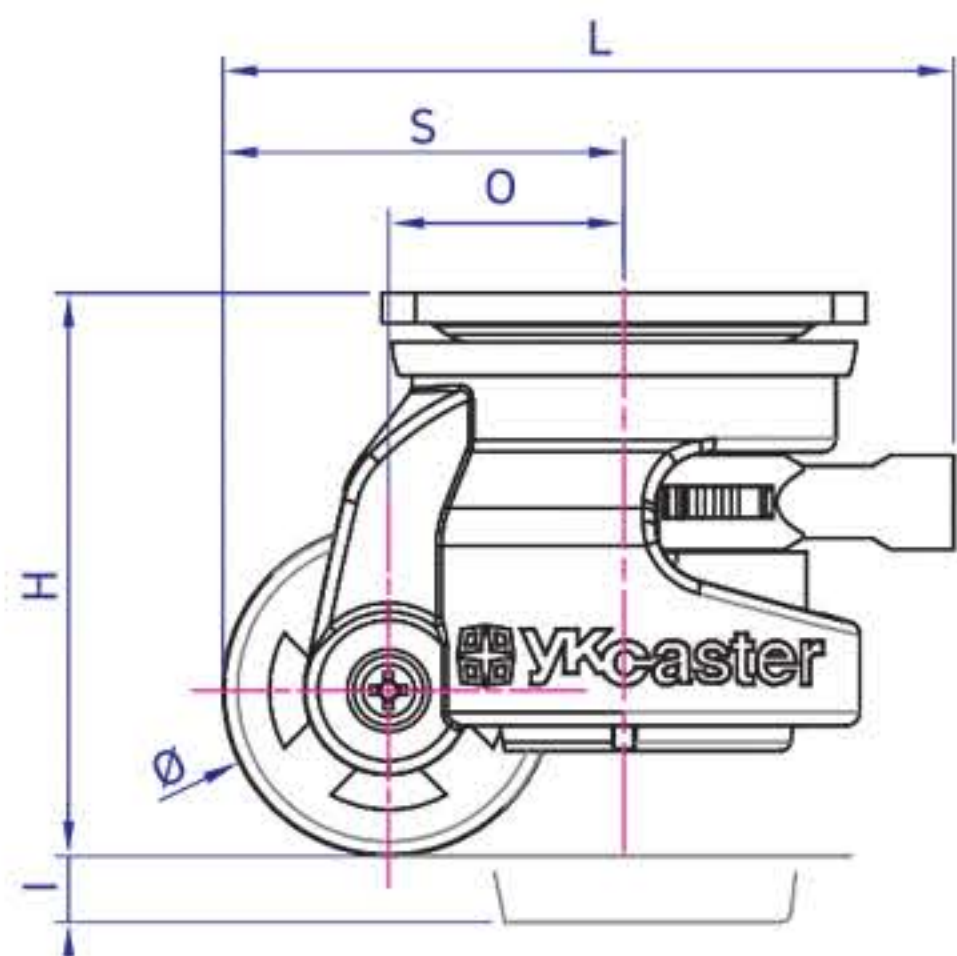
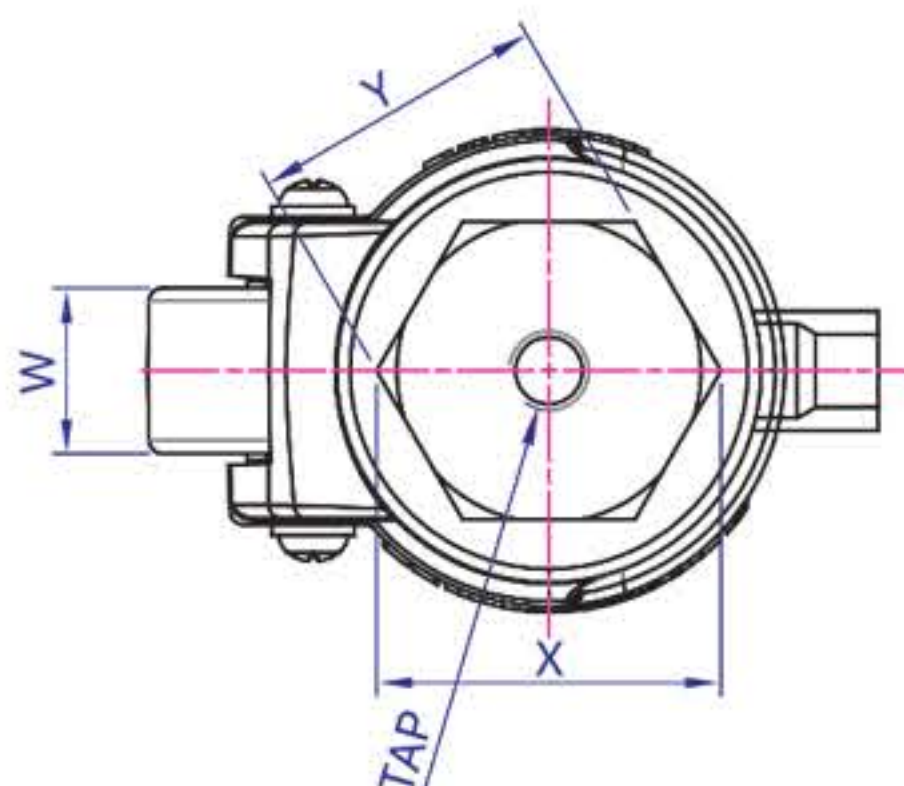
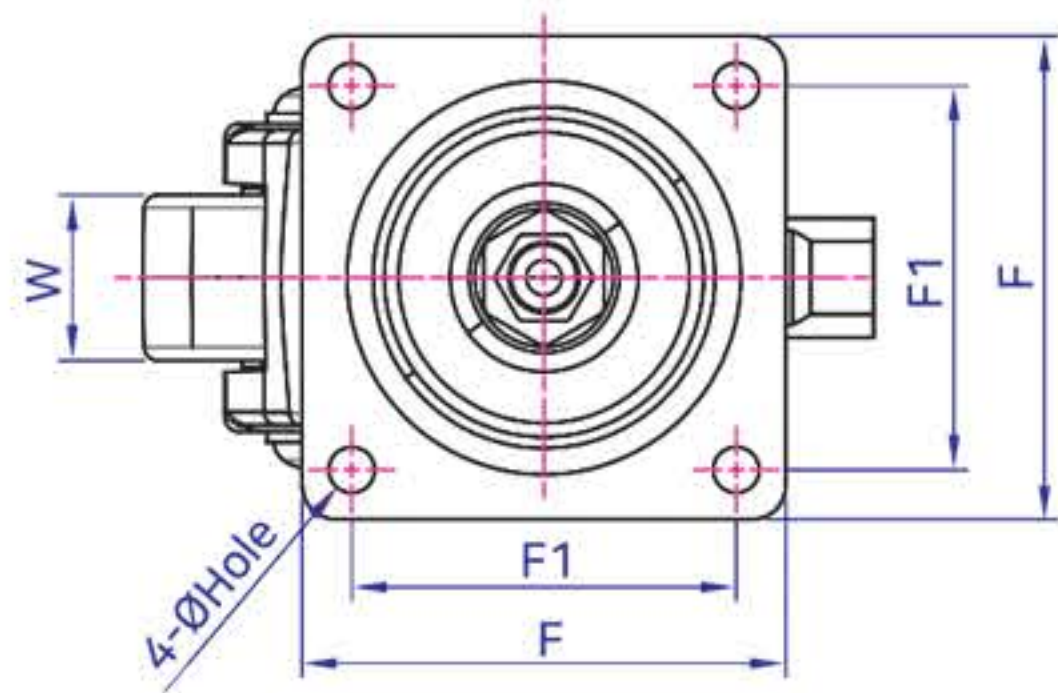

F

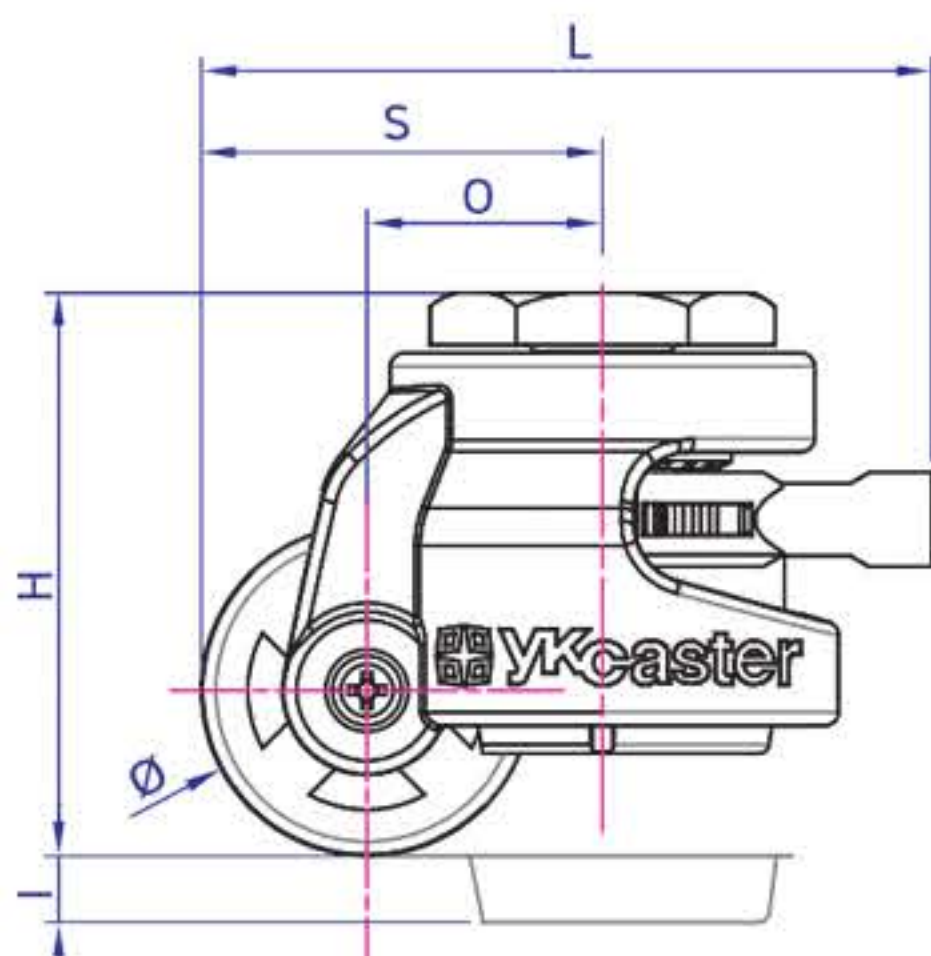

S

규격 DIMENSION

MODEL	자중 (Net weight) Kg		Ø W		F F1 Hole			TAP (Order) X Y		H+I L S O				
	kg	1EA	4EA	Ø	W	F	F1	Hole	X	Y	H+I	L	S	O
YKCT-AR60F	1.2	250	500	Ø50	25	73x73	58x58	Ø7 (Ø8.5)	-	-	85+10	110.2	60.5	35.5
YKCT-AR60S	1.02					-	-	-	M12	52				
YKCT-AR80F	2.02	500	1,000	Ø63	30	90x90	70x70	Ø9	-	-	103+10	126.3	76.6	45
YKCT-AR80S	1.8					-	-	-	M12	70				
YKCT-AR100F	2.02	500	1,000	Ø63	30	90x90	70x70	Ø9	-	-	103+10	126.3	76.6	45
YKCT-AR100S	1.8					-	-	-	M12	70				