

The use or communication of the contents there of are forbidden without express authority. (당사의 사전 허락없이 무단 전제 및 복사를 금함)

NO	REVISION RECORD	DATE	CHK.	APPR.

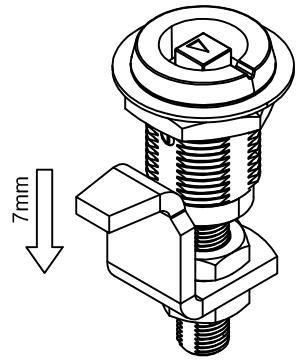

CC-2020-2

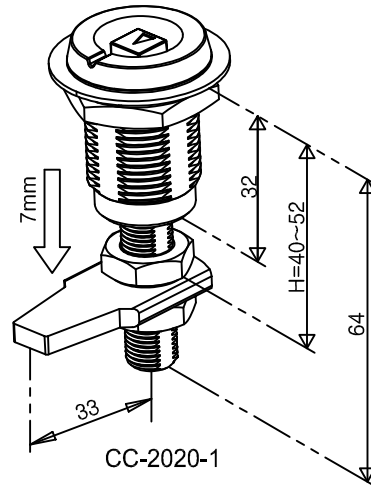
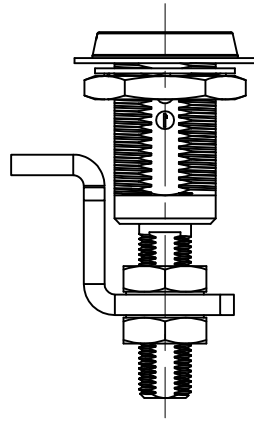

CC-2020-1

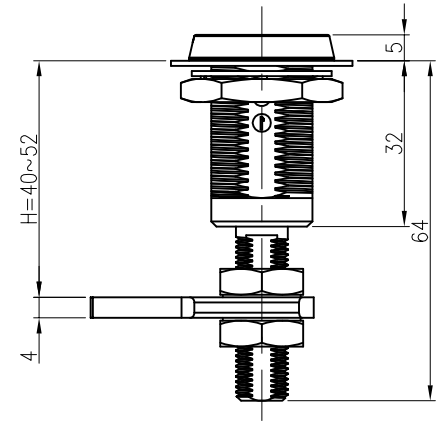

품 명	GH
CC-2020-1	0
CC-2020-2	27

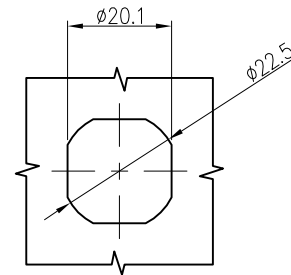
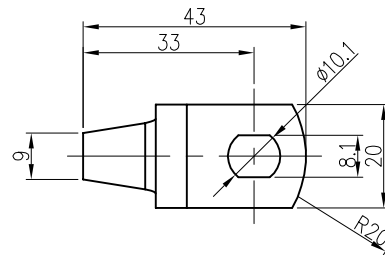
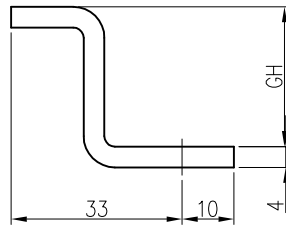

PANEL DRILLING DIMENSIONS

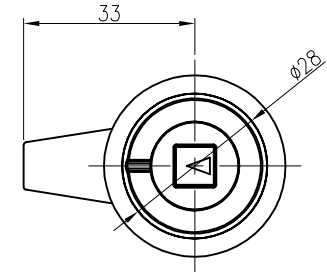

TOLERANCE(mm)  
(KS B 0412에 준함)

6 이하	±0.05
6 ~ 30	±0.1
30 ~ 120	±0.15
120 ~ 315	±0.2
300 ~ 1000	±0.3
1000 ~ 2000	±0.5

Note

1. 특징 :
2. 예도 :

FINISH	MATERIAL	UNIT	mm	NO.	DESCRIPTION	DWG. NO	QTY	REMARK
도금 : Zinc plating 도장 : Black	아연함금 (Zinc) Cam=Steel	APP. DWG.	2020.06.30		DWG. NO. PART NAME	-	-	V1.0
QTY	Hardware			1/1	ASS'Y NAME	compression cam lock		
1 EA/SET				A3	MODEL NO.	CC-2020		