

The use or communication of the contents there of are forbidden without express authority. (당사의 사전 허락없이 무단 전제 및 복사를 금함)

NO	REVISION RECORD	DATE	CHK.	APPR.

CC-1080-1

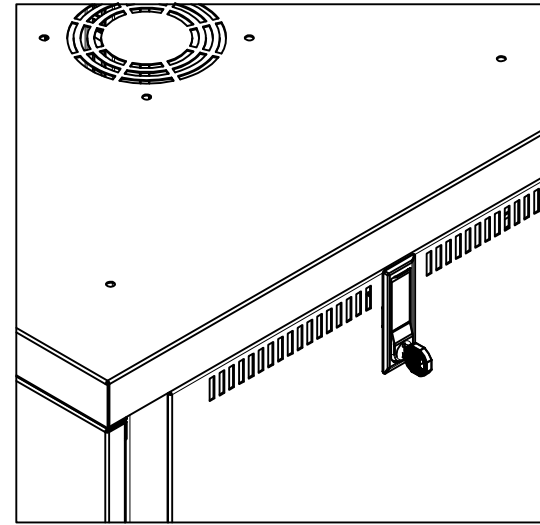
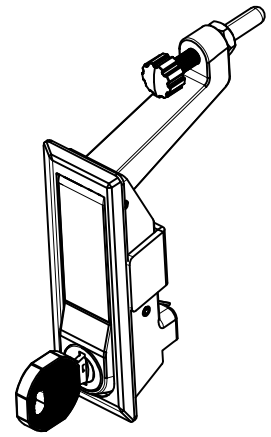

CC-1080-2

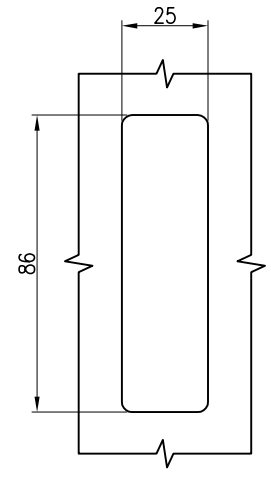
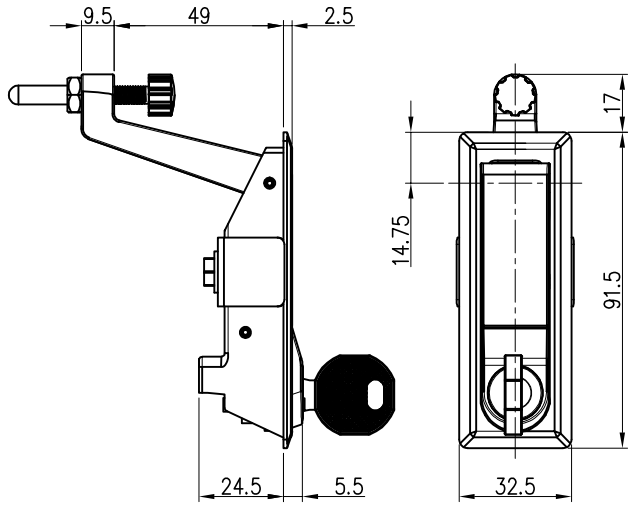
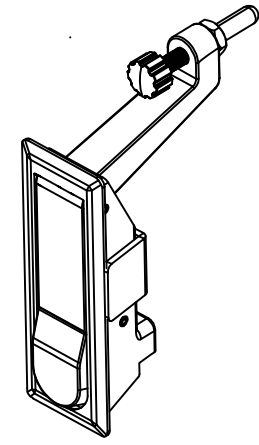

Panel Drilling Dimensions

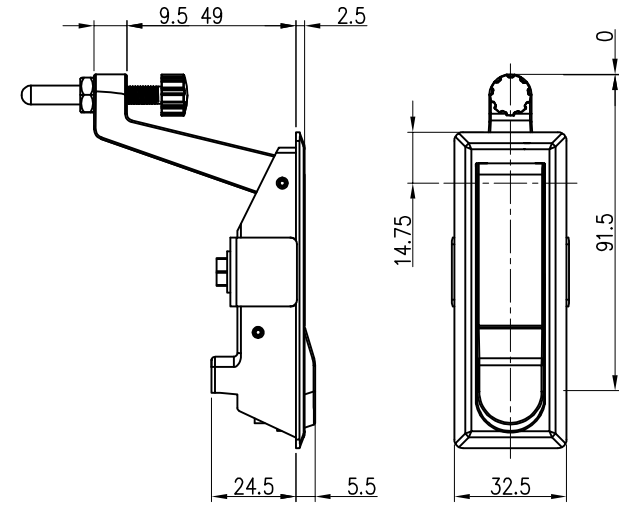

TOLERANCE(mm) (KS B 0412에 준함)	
6 이하	±0.05
6 ~ 30	±0.1
30 ~ 120	±0.15
120 ~ 315	±0.2
300 ~ 1000	±0.3
1000 ~ 2000	±0.5

Note
 1. 특징 :
 2. 용도 :

FINISH	MATERIAL	UNIT	mm	NO.	DESCRIPTION	DWG. NO	QTY	REMARK
도금 : - 도장 : -	SUS 316	APP. DWG.	2020.04.30	1/1	DWG. NO. PART NAME ASS'Y NAME	-	-	V1.0
QTY	Hardware			1/1	MODEL NO.	SUS 316 Compression Latch		
1 EA/SET				A3	CC-1080			