

The use or communication of the contents there of are forbidden without express authority. (당사의 사전 허락없이 무단 전제 및 복사를 금함)

NO	REVISION RECORD	DATE	CHK.	APPR.

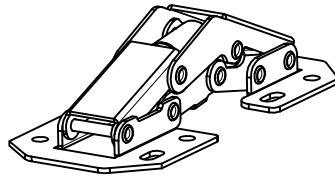

멤퍼기능
(Soft Closing)

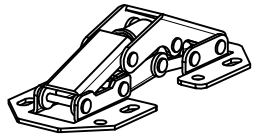
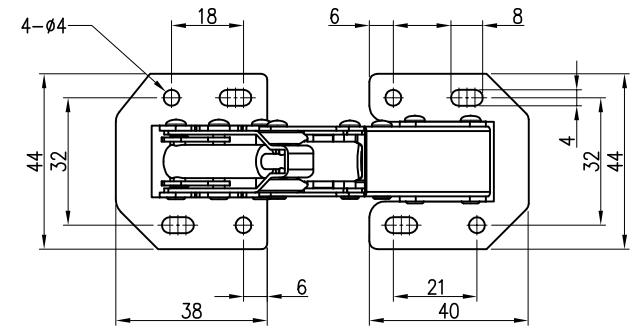
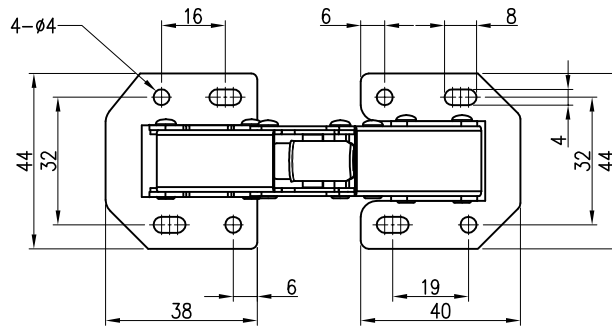
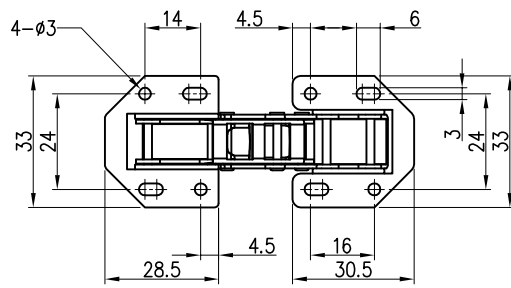
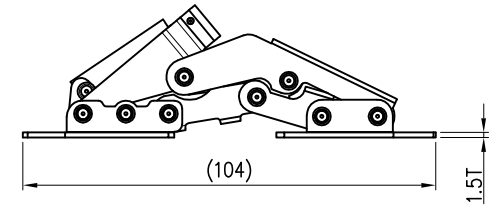
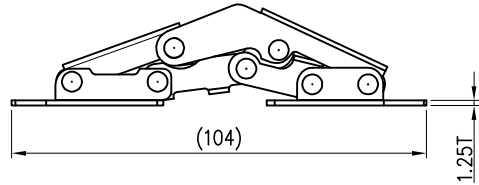
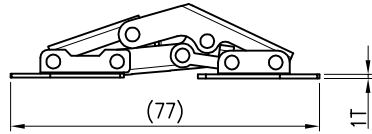
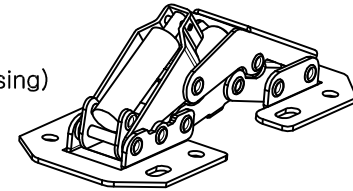

CH6060

CH6050

CH6030

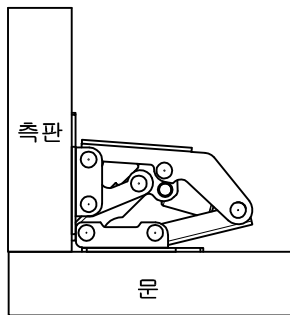

Without spacer plate

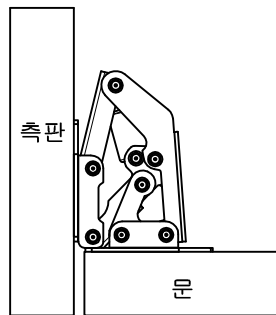

Hinge turned

TOLERANCE(mm) (KS B 0412에 준함)	
6 이하	±0.05
6 ~ 30	±0.1
30 ~ 120	±0.15
120 ~ 315	±0.2
300 ~ 1000	±0.3
1000 ~ 2000	±0.5

FINISH	MATERIAL	UNIT	mm	NO.	DESCRIPTION	DWG. NO	QTY	REMARK
니켈도금	Cold-Rolled Steel t=1.0/1.25/1.5	APP. DWG.	2021.01.25		DWG. NO. PART NAME	-	-	V1.0
QTY	Hardware			1/1	ASS'Y NAME	-		
1 EA/SET	A3			MODEL NO.	CH6060 & 6050 & 6030			