

The use or communication of the contents there of are forbidden without express authority. (당사의 사전 허락없이 무단 전제 및 복사를 금함)

NO	REVISION RECORD	DATE	CHK.	APPR.

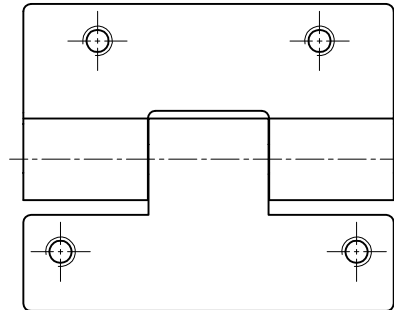
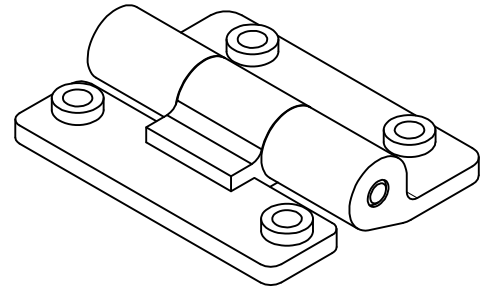
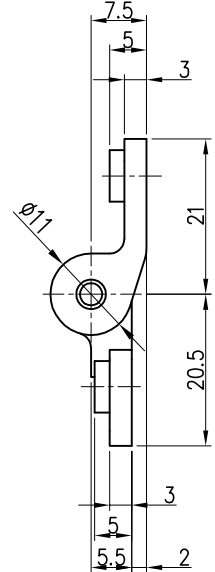
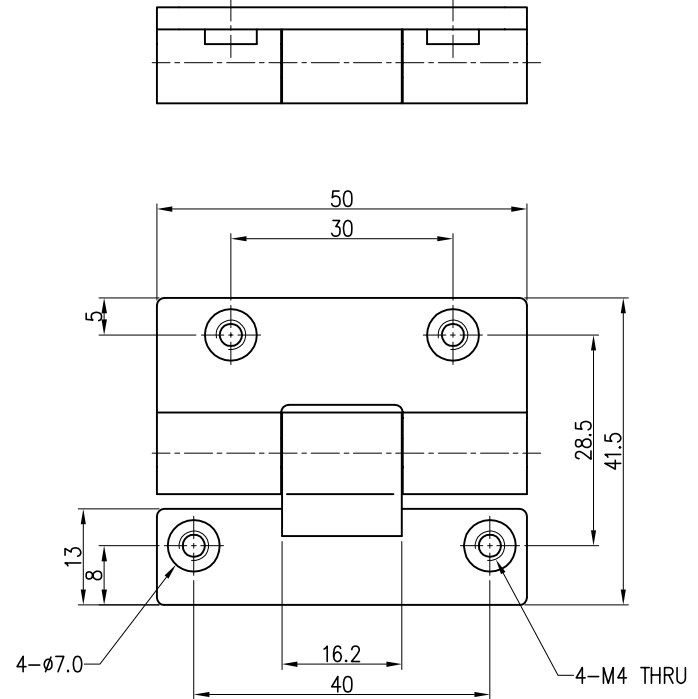

TOLERANCE(mm) (KS B 0412에 준함)	
6 이하	±0.05
6 ~ 30	±0.1
30 ~ 120	±0.15
120 ~ 315	±0.2
300 ~ 1000	±0.3
1000 ~ 2000	±0.5

Note
 1. 규격 :
 2. 재료 :

제품명	Color	부하토크(kgf.mm)
CH-ADG-A01-B-1	Black	40 ~ 55 kgf.mm
CH-ADG-A01-B-2		95 kgf.mm
CH-ADG-A01-B-3		120 kgf.mm
CH-ADG-A01-B-4		180 ~ 210 kgf.mm
CH-ADG-A01-S-4	Silver	180 ~ 210 kgf.mm

FINISH	MATERIAL	UNIT	mm	NO.	DESCRIPTION	DWG. NO	QTY	REMARK
도금 : -	ZDC11	APP.	2018.11.20	S,H,KIM	DWG. NO.	-	-	V1.0
도장 : BLACK/SILVER	CASTING	DWG.	2018.11.20	S,H,OH	PART NAME	-	-	-
QTY	Hardware			1/1	ASS'Y NAME	토크 원지		
1 EA/SET	A3			MODEL NO.	CH-ADG-A01			