

Dwg. No.

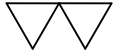

Rev. No.	DESCRIPTION	DATE	DS.	CH.	AP.
△					
△					
△					

unit : mm

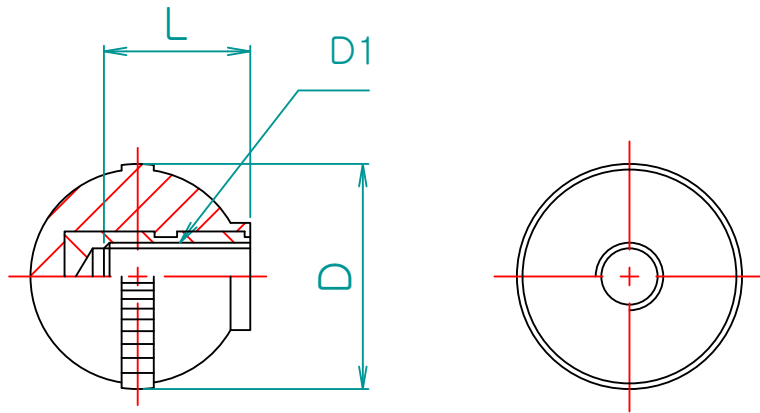

제품명	D1	볼 색	L	D
PBI 20	M6	B(흑색) R(적색) G(녹색)	13	20
	M5			
PBI 25	M8		13	25
	M6			
PBI 30	M10		15	30
	M8			
	M6			
PBI 32	M10		15	32
	M8			
	M6			
PBI 35	M12		20	35
	M10			
	M8			
PBI 40	M6	20	40	
	M12			
	M10			
PBI 50	M8	20	50	
	M12			
	M10			

	재 질	표면처리
노브부	페놀수지	적, 녹, 흑색유광
나사부	황동(인서트)	-

Note

1. 특징 :

2. 용도 :

Dimension (mm)	Precision	Material	Dwg. No.	Q'TY
0.5~3		페놀수지		**
3~6	±0.05	Finish	Part Name.	Weight
6~30	±0.1	흑색유광	**	-
30~120	±0.15	Revision	Ass'y Name	Scale
120~315	±0.2	-	**	1:1
315~1000	±0.3	Date	Designed by	Model No.
1000~2000	±0.5	2010-09-07	Shin S H	PBI
		Checked by	Approved by	
		KS B 0412에 준함		

Hardware