

The use or communication of the contents there of are forbidden without express authority. (당사의 사전 허락없이 무단 전제 및 복사를 금함)

NO	REVISION RECORD	DATE	CHK.	APPR.

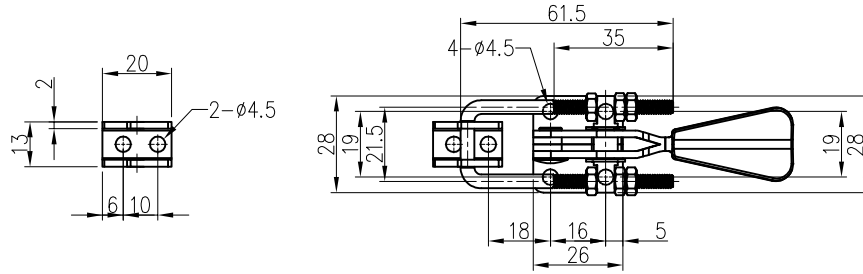

CR-1001-01/ 2001-01

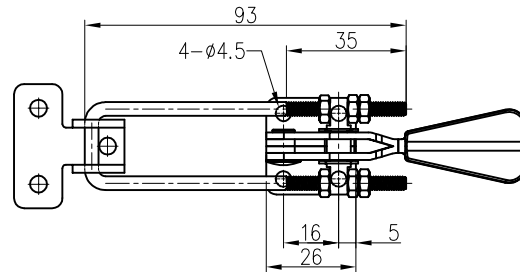
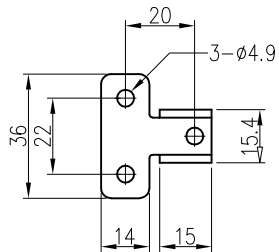
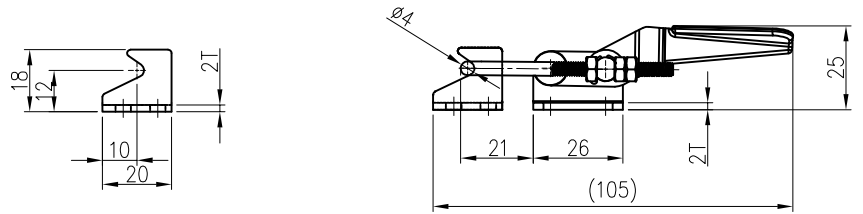

CR-2001-01F(목공용)

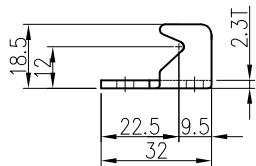

CR-1001-01/ 2001-01

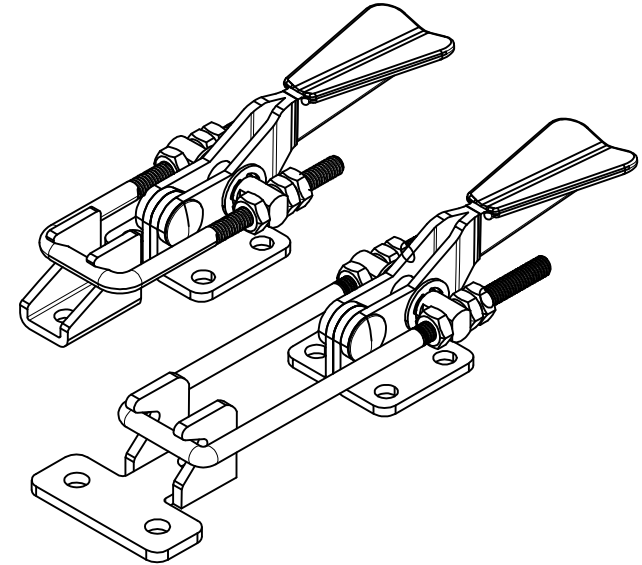

CR-2001-01F(목공용)

품 번	재 질	표면처리
CR-1001-01	STAINLESS	바렐연마
CR-2001-01	STEEL	아연도금
CR-2001-01F	STEEL	아연도금

TOLERANCE(mm)
(KS B 0412에 준함)

6 이하	±0.05
6 ~ 30	±0.1
30 ~ 120	±0.15
120 ~ 315	±0.2
300 ~ 1000	±0.3
1000 ~ 2000	±0.5

Note

1. 특 징 :
2. 재 질 :

FINISH	MATERIAL	UNIT	mm	NO.	DESCRIPTION	DWG. NO	QTY	REMARK
도금 : - 도장 : -	Stainless/Steel	APP.			DWG. NO.	-		V1.0
		DWG.	2019.07.05		PART NAME			
QTY				1/1	ASS'Y NAME			
1 EA/SET	Hardware			A3	MODEL NO.	CR-1(2)001-01F		