

The use or communication of the contents there of are forbidden without express authority. (당사의 사전 허락없이 무단 전제 및 복사를 금함)

NO	REVISION RECORD	DATE	CHK.	APPR.

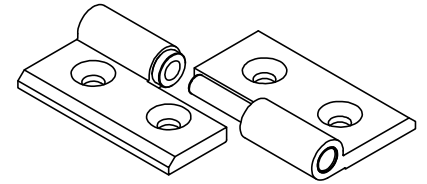
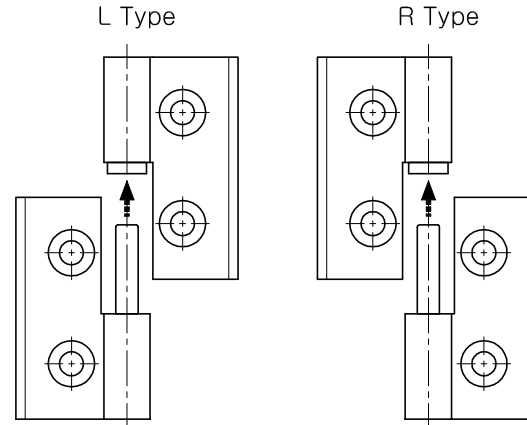
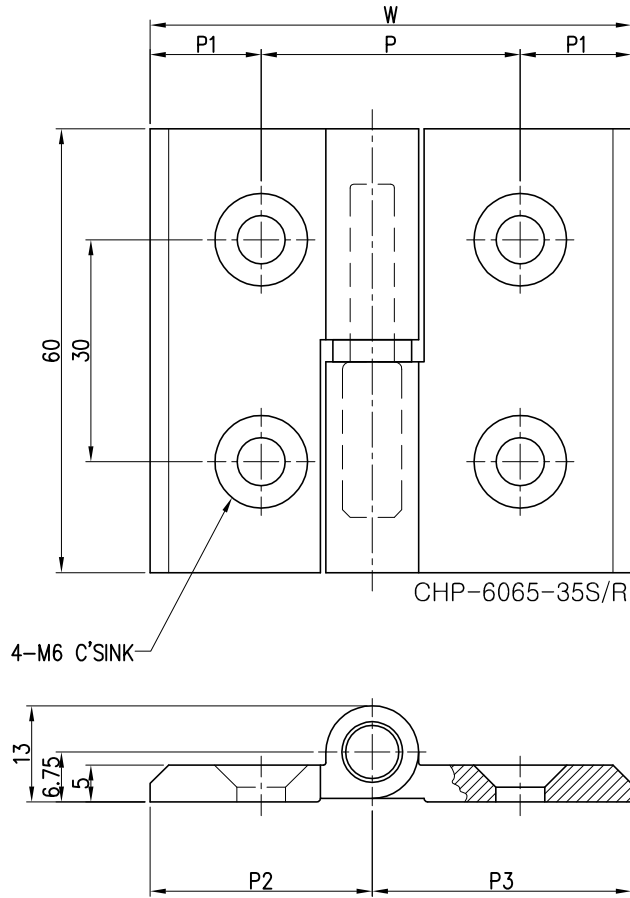

unit : mm

제 품 명	W	P	P1	P2	P3	Color	Type
CHP-6060-30S	60	30	15	30	30	Silver	R / L
CHP-6060-30B						Black	
CHP-6060-31S	60	31	14.5	30	30	Silver	
CHP-6060-31B						Black	
CHP-6065-35S	65	35	15	30	35	Silver	
CHP-6065-35B						Black	
CHP-6065-36S	65	36	14.5	30	35	Silver	
CHP-6065-36B						Black	
CHP-6070-40S	70	40	15	35	35	Silver	
CHP-6070-40B						Black	
CHP-6070-41S	70	41	14.5	35	35	Silver	
CHP-6070-41B						Black	

TOLERANCE(mm)
(KS B 0412에 준함)

6 이하	±0.05
6 ~ 30	±0.1
30 ~ 120	±0.15
120 ~ 315	±0.2
300 ~ 1000	±0.3
1000 ~ 2000	±0.5

FINISH	MATERIAL	UNIT	mm	NO.	DESCRIPTION	DWG. NO	QTY	REMARK
도금 : 알루미늄	AL6061	APP.	2018.11.20	S,H,KIM	DWG. NO.	-	-	V1.0
도장 :	EXTD	DWG.	2018.11.20	S,H,OH	PART NAME	-	-	-
QTY				1/1	ASS'Y NAME	알루미늄 압출 피봇 경첩		
1 EA/SET	Hardware			A3	MODEL NO.	CHP-60xx-xxx		