

Dwg. No.

Re. No.	DESCRIPTION	DATE	DS.	CH.	AP.
△					
△					
△					

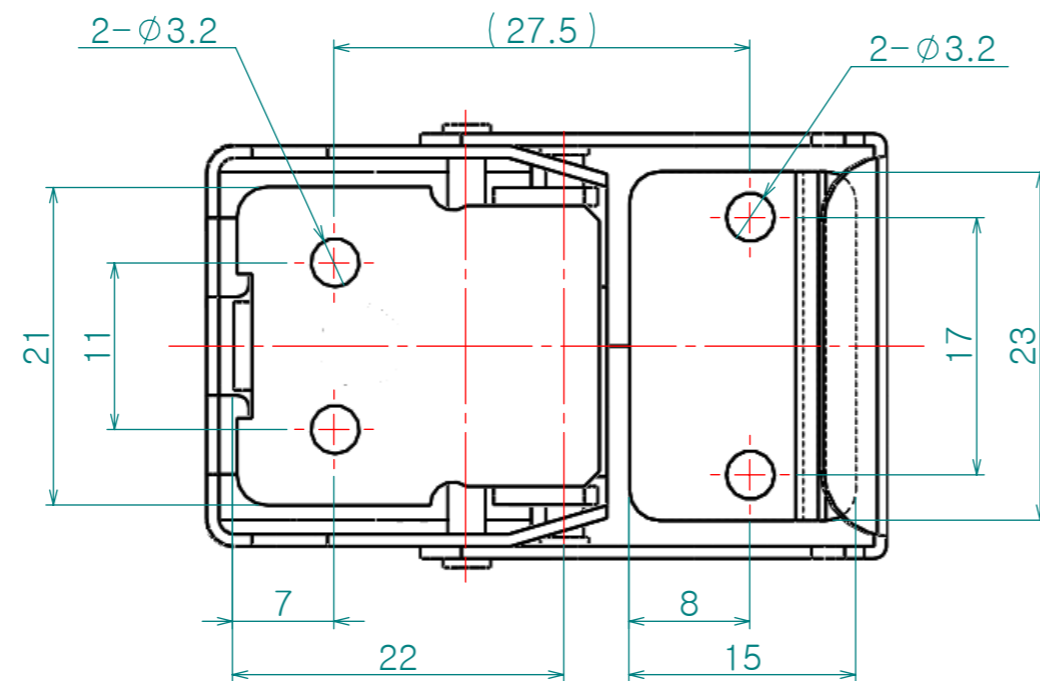
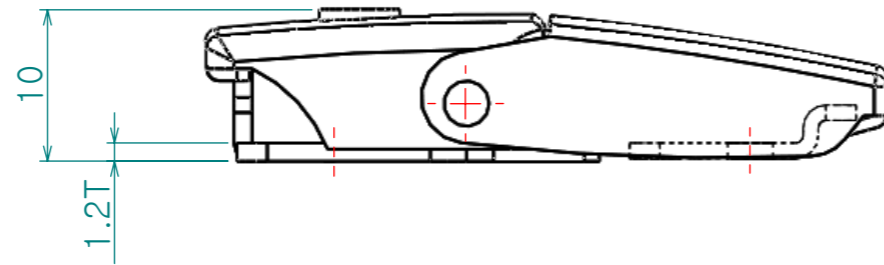
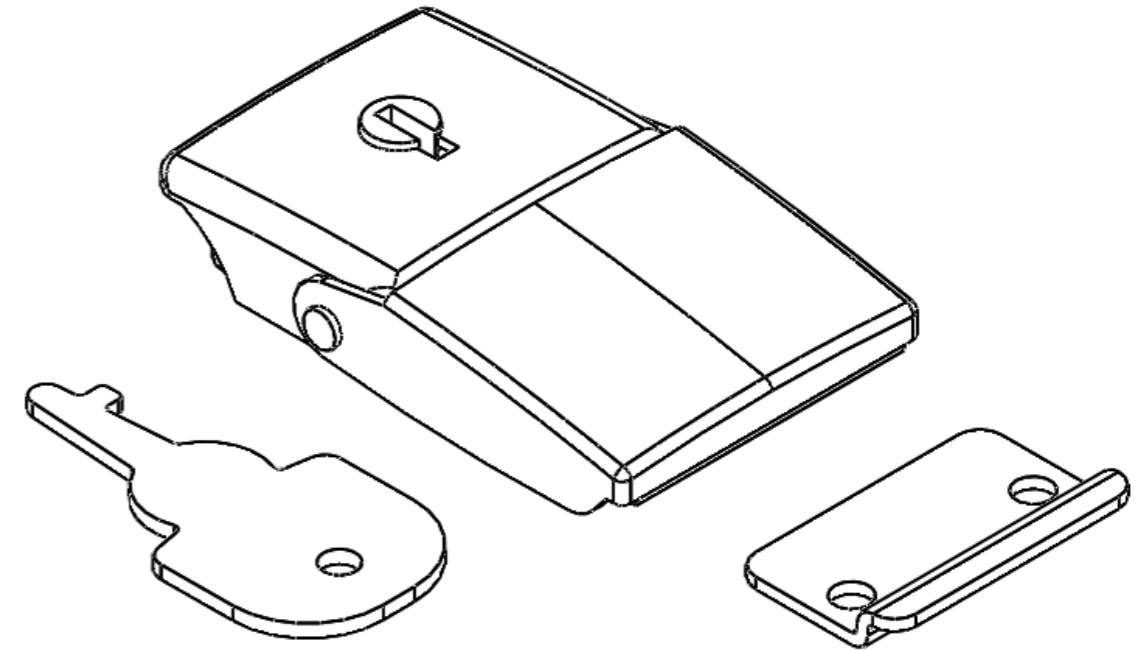
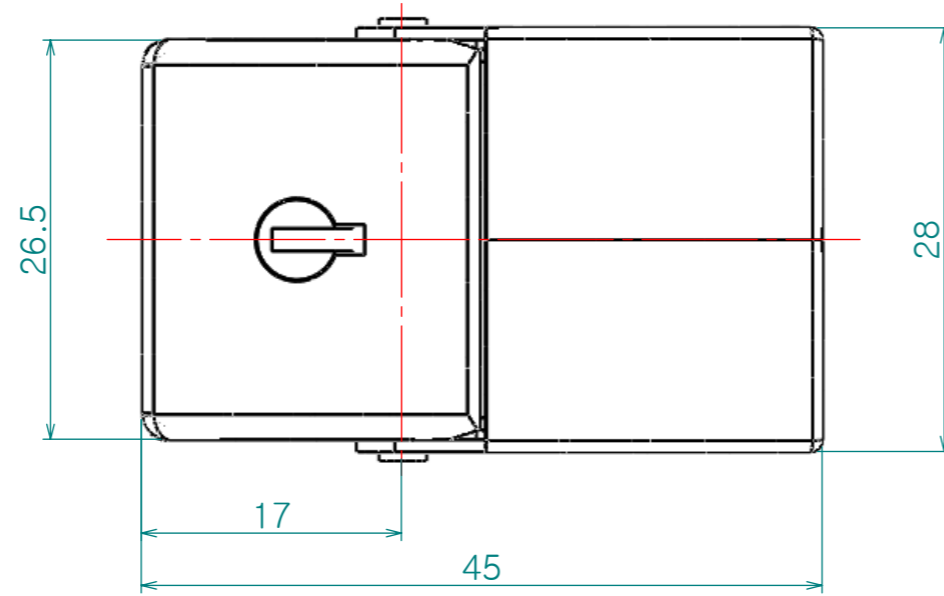
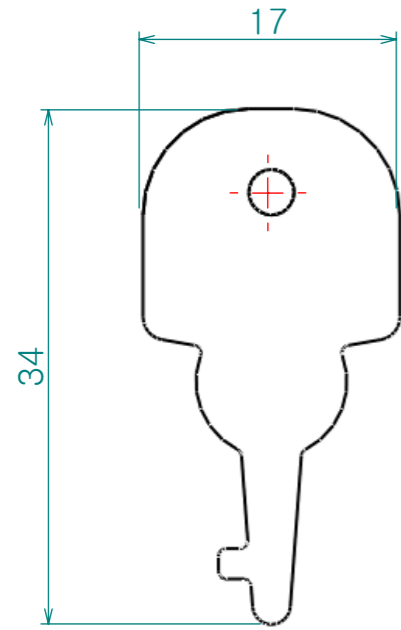

Note

1. 특징 :

2. 용도 :

Dimension (mm)	Precision	Material	Dwg. No.	QTY	
0.5~3	±0.05	냉간압연강판(SPCC)	Part Name.	**	
3~6		Finish		**	Weight
6~30	±0.1	크롬도금(MBCr)	Ass'y Name	-	
30~120	±0.15	Revision	Sheet Size	Scale	
120~315	±0.2	-	A3	2:1	
315~1000	±0.3	Date	Designed by	Model No.	
1000~2000	±0.5	2016-02-18	Shin S H		CC-1074
KS B 0412에 준함		Checked by	Approved by		