

Dwg. No.

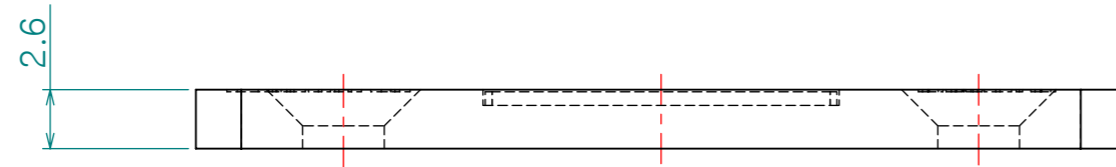

Re. No.	DESCRIPTION	DATE	DS.	CH.	AP.
△					
△					
△					

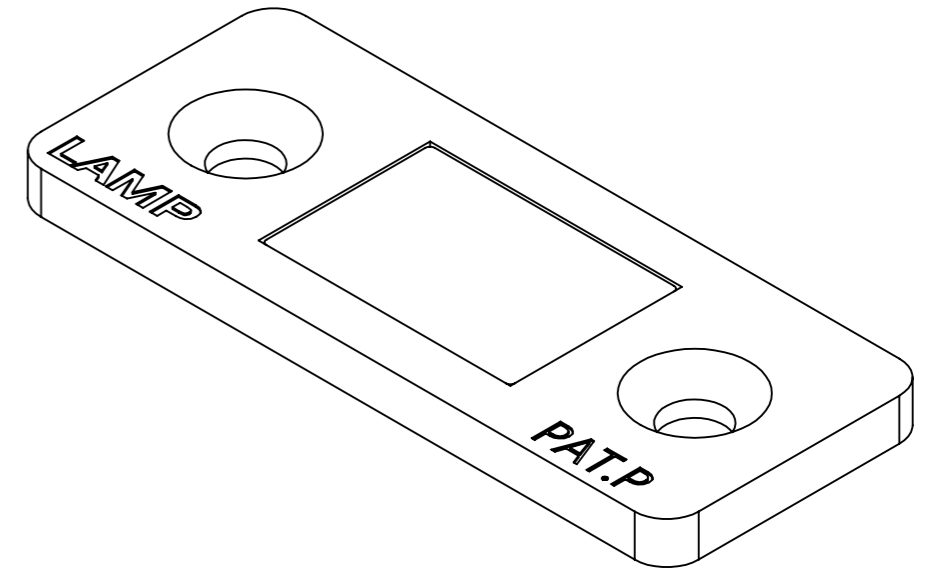
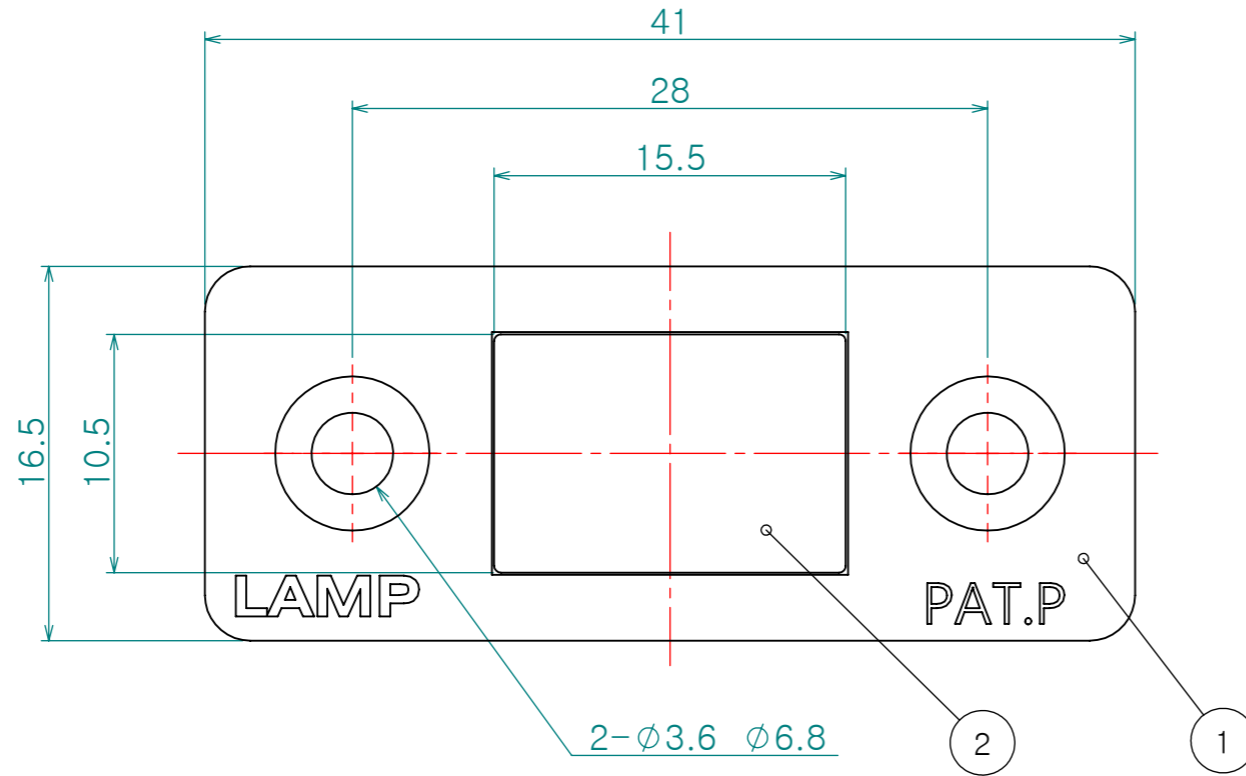

No.	부 품 명	재 질	표면처리
①	Body	Steel	Nickel
②	Magnet	Neodymium	Nickel

제 품 명	흡 착 력		제품무게
CC-MC-158	14.7N	1.5kgf	12g
CC-MC-159	39N	4kgf	12g

Note

1. 특징 :

2. 용도 :

Dimension (mm)	Precision	Material **	Dwg. No.		QTY *EA	
0.5~3	±0.05	Finish **	Dwg. No.		*EA	
3~6			Part Name. **		Weight -	
6~30	±0.1	Revision -	Sheet Size <b>A3</b>	Ass'y Name **	Scale 3:1	
30~120	±0.15		Date 2013-09-08	Designed by <i>Shin S H</i>	Model No. <b>CC-MC-158</b>	
120~315	±0.2		Checked by	Approved by		
315~1000	±0.3					
1000~2000	±0.5					
KS B 0412에 준함						